



DOG CLUTCH SOLENOID

Peak and Hold Disconnect Solenoid

Solenoid pin extends out when an electrical current is applied. After solenoid has fully stroked and reached internal end stop, current is reduced to optimize power consumption while still outputting high force. The solenoid can be used for applications requiring fast, high force actuation such as clutch connect/disconnect.

Solenoid is designed to be external mount with internal components being in an oil splash environment. The solenoid is bolted down to the application manifold. Center Pole pilots and seals into a bore in application manifold. Housing flanges sit flush to mounting surface.

Solenoid is designed to allow for sensor-less position detection to ensure full extend and retract stroke is achieved. Internal noise suppression ensures customer satisfaction by greatly reducing connect/disconnect NVH.

***Technical Data:**

Resistance: $4.1\Omega \pm 0.25$ @ 20°C

Inductance: 95mH to 180mH $\pm 15\%$ at @ 20°C (0-9.33mm)

Stroke: 9.33 mm nominal

Force: >250N across 2/3rds of stroke @ Peak current (5.4A)
>250N at end of stroke @ Hold current (1.23A)

Force Stroke Characteristic: See next page

Response Time: 35ms

Mating connector: Hirschmann 872-858-521

***Operating Limits:**

Current: 1.36A continuous MAX at 150°C in splash oil

Voltage: 35 V MIN required for 5.4 A @ 150°C

Oil Temp: -40°C to 150°C

* Contact Husco engineering for customized performance and solenoid environment.



Husco's Automotive team specializes in collaborative development of customized performance solutions. Contact the engineering team for your custom solution.

inquiries@huscoauto.com | (262) 513-4200 | Husco.com



Typical Force Stroke Curve

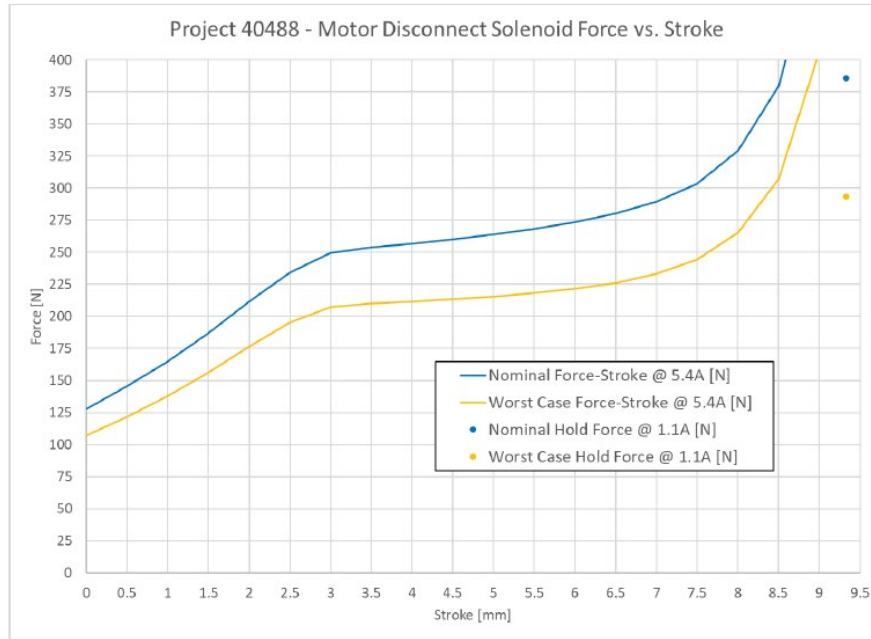

*Standard performance curves shown. For custom performance, contact Husco engineering.

Nominal Size

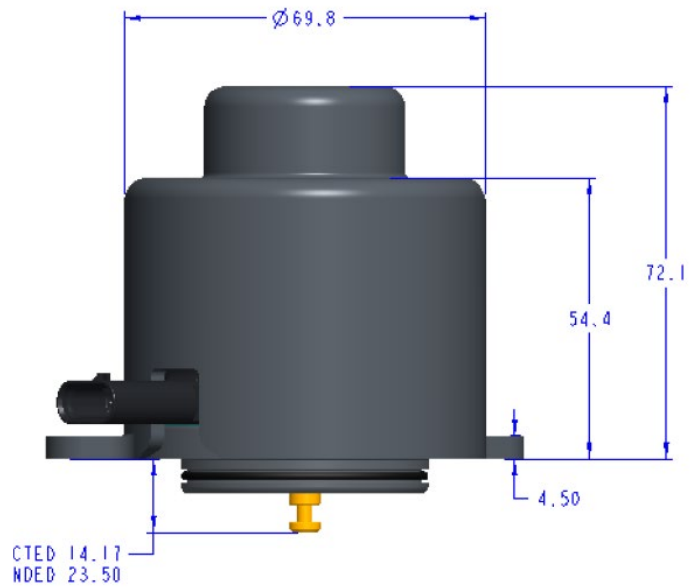

Husco's Automotive team specializes in collaborative development of customized performance solutions. Contact the engineering team for your custom solution.

inquiries@huscoauto.com | (262) 513-4200 | Husco.com