



# BRUSHED DC ACTUATOR

## Rotary Actuator with Internal Gearbox

A rotary actuator that is capable of up to 2 Nm (17.7 in-lbs) continuous and 3.3 Nm (29.2 in-lbs) boost torque at 6 RPM. This actuator provides higher torque than comparable actuators on the market allowing for actuation of valves, dampers, mechanisms, or other automotive applications. A physical internal rotary sensor provides absolute position feedback, which is especially desirable for applications where accurate real-time position data is important for critical system- level protection and fail-safe functionality.

The actuator includes a brushed DC motor and gearbox to generate and transmit torque, and features an on-board controller which includes LIN communication, on-board rotary position sensing, position control, bootloader capability, and diagnostics. Gear drive is designed to minimize hold power. Flexible mounting and output options are available. Fail-safe position of the output shaft can be communicated in the event of communication loss or component failure.

### \*Technical Data:

**Rotation Range:** 355°

**Torque (nominal):** ±2Nm

**Torque (boost<sup>^</sup>):** ±3.3Nm

**Speed:** 6RPM

**Current (continuous):** 1A max

**Current (boost<sup>^</sup>):** 1.5A max

**NVH:** <50dbA

**LIN Communication:** LIN protocol 2.1 version, Baud rate 19.2 kbs

**Internal Rotary Sensor:** ±3% accuracy



<sup>^</sup>Duty cycle at Boost Torque Level expected to be <20%

### \*Operating Limits:

**Supply voltage nominal:** 12 ± 1 VDC

**Supply voltage range:** 9 to 16 VDC

**Temperature:** -40°C to 85°C

**Ingress Protection:** IP6K7



\*Contact Husco engineering for customized performance, sensing, mounting, communication, diagnostics, ingress protection, or connectors,



Husco's Automotive team specializes in collaborative development of customized performance solutions. Contact the engineering team for your custom solution.

[inquiries@huscoauto.com](mailto:inquiries@huscoauto.com) | (262) 513-4200 | [Husco.com](http://Husco.com)



# Packaging Size

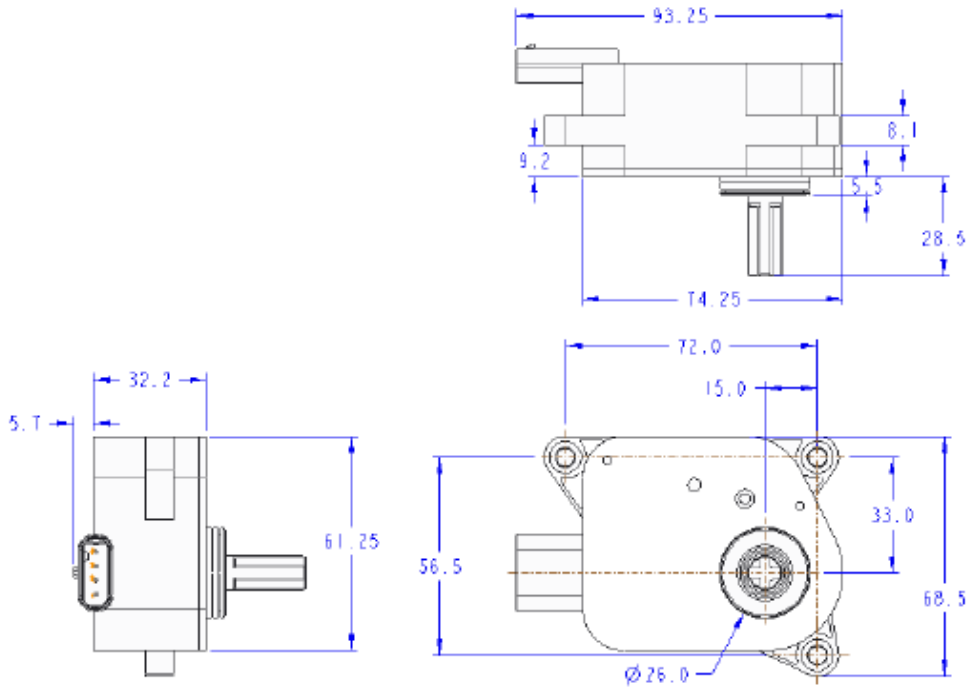

## Partner with Husco

Husco develops comprehensive automotive solutions that drive performance, including systems and components for electric, hybrid and internal combustion engine vehicles.

Husco is a global company with facilities around the world. Options for manufacturing locations include North America, Europe, and Asia.

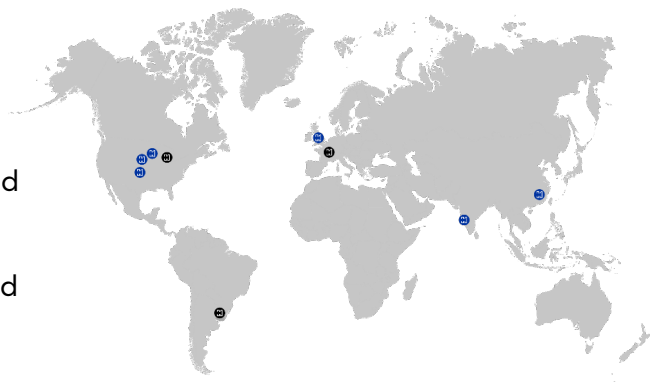

Husco's Automotive team specializes in collaborative development of customized performance solutions. Contact the engineering team for your custom solution.

[inquiries@huscoauto.com](mailto:inquiries@huscoauto.com) | (262) 513-4200 | [Husco.com](http://Husco.com)